

Considerations When Restraining Molecularly Oriented PVC Pipe

GM Quesada^{1*} and KH Steinbruck²¹Product Development Engineer Simulation Driven Engineering Pozos, Santa Ana, Costa Rica²Steinbridge LLC Eugene, Oregon, USA***Corresponding author**

GM Quesada, Product Development Engineer Simulation Driven Engineering Pozos, Santa Ana, Costa Rica.

Received: July 28, 2025; **Accepted:** August 01, 2025; **Published:** August 11, 2025**Keywords:** PVC-O, O-PVC, Joints, Restrained**Introduction**

The benefits of molecularly oriented PVC pipe (PVC-O) are well known and documented. Numerous studies covering improved pipe impact, toughness, hydraulics, and life cycle have been published. There is less information about PVC-O pipe under pipeline hydraulic forces. The objective of this paper is to identify design considerations when restraining PVC-O pipe.

**Components Tested
Pipe**

Diameters tested included 6" (150 mm) and 8" (200 mm), PC 235, according to AWWA C909 Molecularly Oriented Polyvinyl Chloride (PVCO) Pressure Pipe, 4 In. through 24 in. (100 mm through 600 mm) for Water, Wastewater, and Reclaimed Water Service.

Restraint Devices

Specimen assemblies included restrained end caps, spigot-to-spigot couplings, and spigot-to-gasketed sockets.

Table 1: List of Joint Restraints Tested.

Type	Code	Description
Restrained End Cap	MGC	Equally spaced actuating-screws load grippers against pipe outside diameter surface
Restrained End Cap	SGC	Single actuating screw slides grippers against pipe outside diameter surface
External Joint Restraint Spigot to Gasketed Socket	S - S	Clamp restraints connected by rods. One set clamps pipe spigot. Second set clamps pipe behind bell.
External Joint Restraint Spigot to Gasketed Socket	S - B	Clamp restraints connected by rods. One set clamps spigot. Second set is snug fit behind gasket raceway.
Internal Joint Restraint Spigot to Gasketed Socket	ICG	Internal metal casing housing a circumferential grip ring that tightens around spigot.

Test Protocol

According to ASTM F1674 Standard Test Method for joint Restraint Products for use with PVC Pipe

- Sustained Pressure Test
500 psi (34.5 bar) for 1,000 hours.
- Minimum Burst Pressure Test
Burst-test pressure for the pipe (755 psi, 5.21 MPa).
Optionally, pressure increased to failure to observe failure mode.
- Cyclic Surge Pressure Test
Cycle base (94 psi, 6.5 bar) to peak pressure (188 psi, 13.0 bar).
6 to 10 cycles per minute

Test Results**ASTM F1674 Section 8.2.2 Sustained Pressure Test****Joint Restraints: S – S And S - B**

Observed: As pressure increased above 200 psi (13.8 bar) visual deformation of joint restraint components was noted. Brittle failure of the spigot occurred at 400 psi (27.6 bar) with the S – B restraint.

**Figure 1: Brittle Failure of Spigot At 400psi**

Finite Element Analysis on a similar joint restraint illustrates the failure mechanism. At 0 psi there is moderate stress on the clamps, as they bend slightly to tighten around the pipe. The rods show uneven tension stress due to initial rotation of the clamps. At 400 psi the rods exceed yield stress under uneven tension. The clamps show a combination of bending and torsion, with stress concentration at the corners where the clamps make contact. The bolts approach yield stress under uneven tension. At 500 psi (34.5 bar) both the clamps and the rods show extensive yield. The gap between the clamps grows due to a 5° clamp rotation.

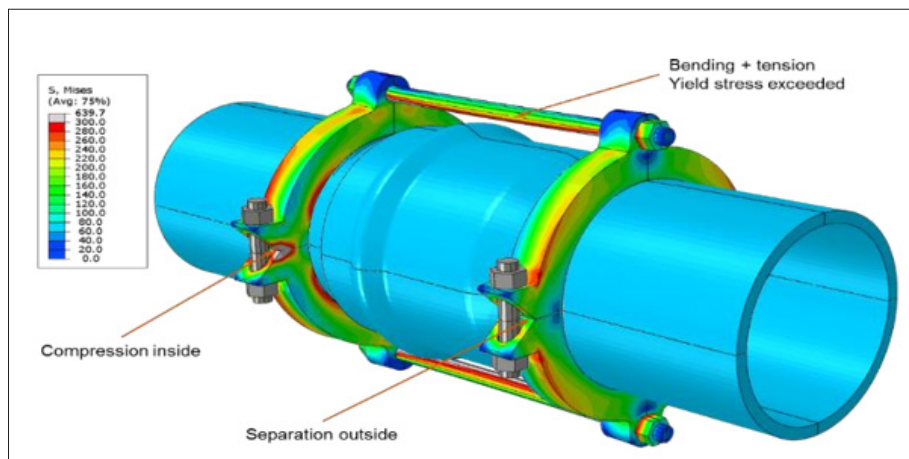

Figure 2: Clamp And Rod Stress in an S-S Joint Restraint At 400psi

Restrained End Cap: MGC

Observed: Pressure increased to 500 psi (34.5 bar) without visual deformation of pipe. Brittle failure of the pipe occurred between 1 hour and 168 hours. The failure nucleated at one of the end caps. The end caps were causal in initiating the pipe failure.

FEA of various mechanical joints shows that the gripping mechanism is not clearly defined. Tightening the mechanical joint does not promote gripping action directly. Instead it increases pressure in the rubber, which is confined between the socket and the gland. This in turn pushes the gripping element against the pipe to enact the gripping action. The main concern is that not having accurate control of the gripping action can lead to insufficient or excessive tightening. This leads to point loading.

Restrained End Cap: SGC

Observed: Pressure increased to 500 psi (34.5 bar) without visual deformation of pipe and attained 1,000 hours without failure. FEA of this end cap was not performed. Comparing with analysis of other joints, this end cap demonstrates characteristics shown to contribute to good performance. Covering most of the pipe circumference with gripping elements, it keeps the grips parallel to the pipe surface, engages the gripping elements uniformly, and uses an adequate number of teeth, properly spaced, shaped, sized and sharpened.

Joint Restraint Coupling: ICG

Observed: Pressure increased to 500 psi (34.5 bar) without visual deformation of pipe and attained 1,000 hours without failure.

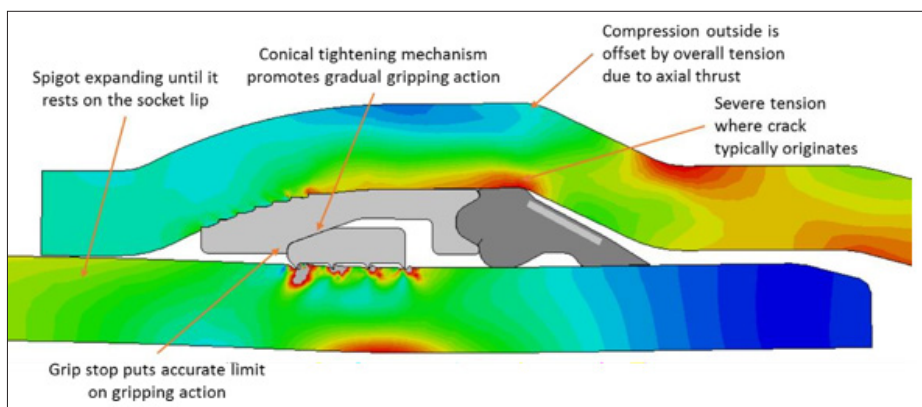

Figure 3: Pipe Stress Distribution in An Ice Joint Above Rated Pressure

FEA of this type of joint has been performed in multiple sizes and configurations. Since this is a push-on joint, at 0 psi the C-grip has not actuated. At about 40 psi (2.6 bar) there is enough axial thrust to engage the C-grip. At rated pressure (235 psi – 16.2 bar) the C-grip is fully engaged. At 500 (34.5 bar) psi the spigot may have expanded until it contacts the lip in the socket. At this point the C-grip has slid along the conical interface in the casing and reached the grip stop. This prevents further tightening which could damage the spigot.

ASTM F1674 Section 8.1.2 Burst Pressure Test

Restrained End Cap: SGC

Observed: As pressure increased pipe began to swell and then burst at 950 psi (65.5 bar). Restrained end cap did not contribute to failure mode.

Joint Restraint Coupling: ICG

Observed: As pressure increased pipe began to swell and then burst at 755 psi (52 bar). Restrained coupling did not contribute to failure mode.



Figure 4: Pipe Burst Away from the Joint.

FEA shows that the most important stress locations are at the grip indentations on the spigot, inside of the spigot (due to wall bending), above the seal apex on the inside of the socket and at the bend at the tail of the seal on the outside of the socket. Although the stress levels are near yield in these spots and exceed yield around the indentations on the spigot, they don't lead to failure. If pressure is increased beyond burst, the greatest damage is at the gripping location in the spigot, where it usually breaks under pure traction (no fluid pressure). Under pressure, this region is contained in the socket lip due to swelling of the spigot, which leads to the spigot most often bursting away from the joint. Key is that the ICG does not contribute to the ultimate failure mode.

ASTM F1674 Section 6.3 Cyclic Surge Pressure Test

Joint Restraints: S – S and S – B

Observed: With initiation of the pressure cycle relative movement of the socketed and plain end lengths of pipe was apparent. During each S - S cycle the spread between the socket lip and spigot measured 3/16" (0.5 cm). At 75,668 cycles the S – S spigot started leaking through a small fracture under a corner of a clamp. At 239,000 cycles the S – B started leaking behind the gasket raceway-groove, under a clamp, and directly below a tie-rod bolt.

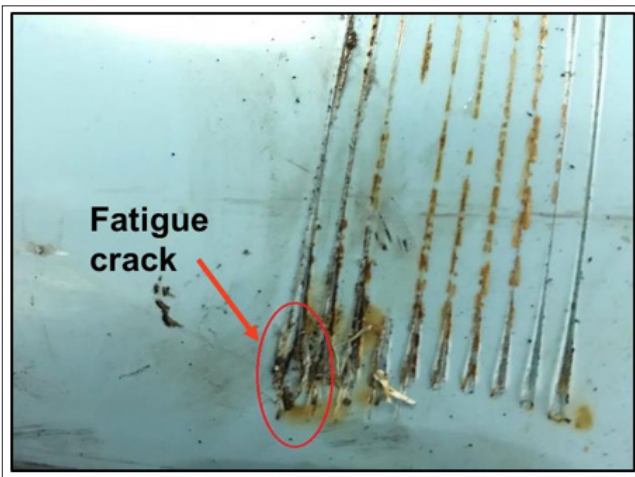

Figure 5: Location Of Fatigue Crack in S – S Joint.

The S – S FEA shows stress concentration at the same location where spigot damage led to leakage. The stress distribution is shown at greater pressure (400 psi – 25.6 bar) to highlight the stress concentration regions. As the clamps rotate and the joint pulls out, one edge produces significantly more contact pressure, which puts the pipe wall in local bending (compression on the outside, tension on the inside). This, in combination with the indentation marks, is a typical mechanism for fatigue failure.

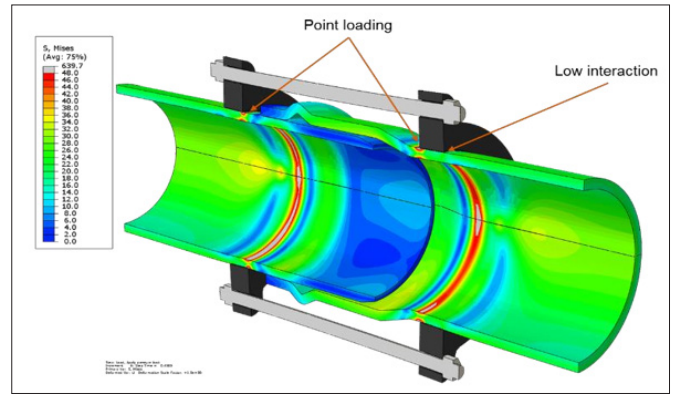

Figure 6: Pipe Stress Distribution in an S - S Joint At 400 Psi (27.6 bar)

Restrained End Cap: MGC

Observed: The assembly reached 1,000,000 cycles.

Joint Restraint Coupling: ICG

Observed: Circumferential crack located at DR 19.4 PVC-U socket major diameter occurring between 615,000 and 675,000 cycles. FEA is consistent with the location of socket cracks. The crack initiates where various factors associated with fatigue failure converge. The change in direction in the socket profile, from axial over the casing to a 30° cone over the seal tail and back to axial at the socket barrel, generates a local bending action. This puts the inside of the socket over the seal apex in tension, while the outside tends to be in compression. This bending action is magnified by the expansion of the socket barrel, while there is no expansion over the casing. Axial stress from pressure thrust offsets the stress distribution, so there is greater tension inside and less compression outside, but the bending mechanism remains. The radius at the apex of the seal, over which the socket is formed, contributes to stress concentration.

Reducing the PVC-U coupling dimension ratio (DR) from 19.4 to 14 mitigates factors associated with fatigue, resulting in test specimens exceeding 1 million cycles.

Discussion

Structural Challenges to Consider when Restraining PVC-O Pipe
As part of a theoretical exercise, metric PVC-U and PVC-O DN200 (PN16) pipe joints with Anger raceways were subjected to twice their nominal pressure and resulting axial thrust in an FEA model. The sockets and the spigots were connected by rigid constraints to emulate an ideal internal restraint. The socket barrels were thickened to preserve the dimension ratio (DR 17 in PVC-U with service coefficient C=2.0, DR 45.8 in PVC-O with service coefficient C=1.4).

The main purpose of this study was to identify the potential weakness of sockets under traction due to internal joint restraints, but it also highlighted how this weakness is magnified by having a relatively thin pipe wall. This is because at every change in direction of the socket profile there is a concentration of bending stress. While stiffness and strength under hoop stress and axial stress are proportional to the wall thickness, stiffness in bending is proportional to the thickness cubed and strength is proportional to thickness squared.

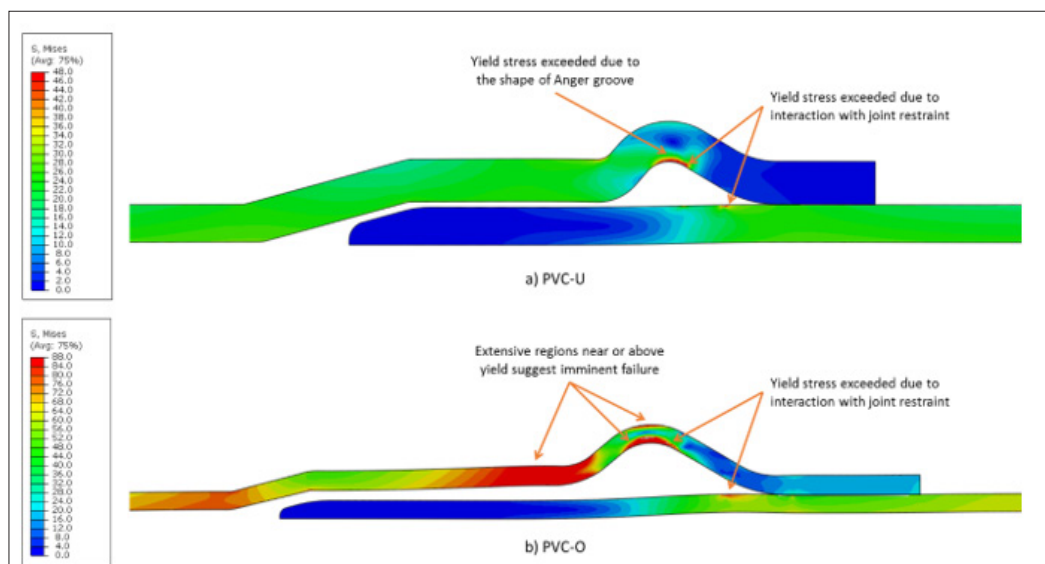

Figure 7: Stress in PVC Joints With Anger Raceways and Ideal Restraints

In the PVC-U joint, the region above the seal shows a bending pattern, with tension exceeding yield stress on the inside, compression on the outside and a neutral region in the middle. In this case the bending pattern is evident, even though it's offset by an overall state of tension from axial thrust. In the PVC-O joint the regions near and above yield turned out more extensive, bringing it to imminent failure.

The comparison above is unfair to PVC-O, since a lower service coefficient is used, which allows a very thin wall. Table 2 shows a fair numerical comparison of PVC-O vs PVC-U, using pipe thickness based on equal design factors according to AWWA C909 and C900 respectively, for 8" class 235 pipe with ASTM D1784 cell class 12454.

The advantage of PVC-O in terms of hydrostatic design basis and yield stress justifies a proportional reduction in wall thickness. This leads to an even comparison in terms of rated pressure, which is based on hoop stress. It even gives a small advantage in pulling capacity and increases the waterway section by 11%. Disadvantages arise when the pipe is subjected to local bending. The strength in bending drops about 40%. Stiffness in bending is worse, as it is affected by the thickness cubed and by a relatively small advantage in elastic modulus. There is also a loss in pipe stiffness.

These disadvantages play against PVC-O joint restraints, since it is impossible to grip a pipe without applying a radial load, which in turn leads to bending. Also, while the pipe wall is harder to indent, it is more flexible in both hoop and bending, so it gets pushed away by the grip more easily than PVC-U.

On the positive side, from thin wall cylinder stress equations, axial stress in a restrained pipe under pressure is only half the hoops stress. Since the pipe is designed for hoop

stress, it ends up with 50% margin in strength under axial stress, which gives some room to deal with the disadvantages described above.

Table 2: PVC-o pipe compared to PVC-u pipe.

Parameter	Units	PVC-O	PVC-U	PVC-O vs PVCU
Hydrostatic design basis	psi	7,100	4,000	+78%
Yield stress	psi	13,000	7,000	+86%
Elastic modulus	psi	465,000	400,000	+16%
Wall thickness	in	0.290	0.503	-42%
Waterway cross area	in ²	56.3	50.8	+11%
Wall section area	in ²	8.0	13.5	-41%
Pressure class (hoop strength)	psi	235	235	-
Local bending strength	lb-in/in	6.2	10.5	-41%
Tensile capacity (axial strength)	lb	28,332	27,012	+5%
Pipe stiffness (pressure/strain)	psi	30,788	47,081	-35%
Pipe Stiffness (bending)	lb/in ²	75.4	364.4	-79%

Design Considerations When Restraining PVC-O Pipe

The general finding is that PVC-O pipe is less tolerant to “collateral loads” than PVC-U.

It demands more rigorous design of joint restraints. Although some considerations are related to installation procedure, a better design will make careful installation less necessary by addressing these issues intrinsically.

Engage The Grips on as Much of the Pipe Circumference as Possible

The practical limit is 100% (360°), which is achieved by clamps. C-grips cover more than 90%. SGC type joints cover more than 80%, still with very good performance. Joints with poor coverage (around 50%) tend to point load the pipe, slip or buckle the walls as they are tightened.

Keep the Gripping Elements Parallel to the Surface of the Pipe.

Since C-grips are made of a single piece, the gripping surface shows very uniform behavior. Wedging segments have a natural tendency to remain parallel to the pipe if they are guided by a conical surface and if this surface is aligned with the pipe as well. Therefore, straight alignment during tightening or engagement is also key. Clamps tend to lose parallelism with the pipe under tensile load, due to the articulation where their ends meet. Increasing torque on the bolts can help mitigate but not eliminate the problem.

Engage The Gripping Elements Evenly Around the Pipe

This is related to the previous consideration. In some cases, the difference can be subtle, or the two considerations can't be separated. In C-grips, if the grip is misaligned it will lead to both lack of parallelism and uneven engagement. The “self-actuating” C-grip in the studied device did an excellent job in maintaining alignment. Wedging segments can be parallel to the pipe and still engage unevenly. In seals featuring integrated wedges a strong reaction from the seal itself is necessary to push the wedges against the cone. In contrast, the SGC end cap did a good job synchronizing the segments, by constraining them with a mechanism driven by a single bolt. Outside diameter clamps engage uniformly if their dimensions are accurate. However, when thrust is applied, they tend to lose uniform engagement together with parallelism.

Use adequate tooth height, shape, sharpness, spacing and number.

The purpose of teeth is to indent the pipe as deep as possible for a secure engagement, while not compromising its integrity. Deeper engagement generates more axial support, but it damages the pipe. Given that the axial stress is only half the hoop stress, in theory the teeth can use up to 50% of the pipe thickness. However, the damage produced by indentation extends beyond its depth and produces stress concentration. Therefore, adequate tooth height should be significantly less than half the pipe thickness.

Tooth shape is characterized by its internal angle. Thin teeth are not advantageous at the beginning of indentation, when sharpness is more important. Once engaged, they indent deeper more easily, but as the pipe gets pulled they show a tendency to leave a gap. They are also weaker, and their height is more sensitive to variations in sharpness. If the teeth are too thick, they find severe resistance to indentation.

Sharpness is critical and limited only by manufacturing. PVC-O would be expected to require greater sharpness than PVC-U. Dull teeth lead to no engagement or catastrophic failure.

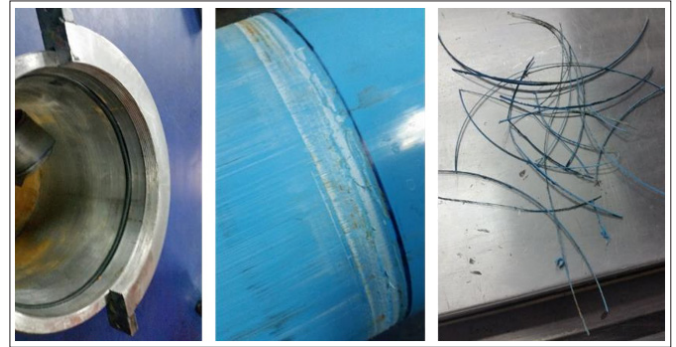

Figure: 8 Clamp grip failure on PVC-O due to too many teeth too close together.

Adequate spacing is necessary to ensure the damage and displacement of material produced by one tooth is isolated from the next one. Teeth too close together interfere with each other's indentation, shaving material off from the pipe and slipping. Adequate spacing is found by FEA and visual inspection of the marks on the pipes.

The number of teeth is often defined by the space available. A single tooth has been found to be effective, but it's not regarded as safe. The grip appears imbalanced, suggesting there is room for at least one more tooth.

Make the gripping element long as possible.

A longer grip makes room for more teeth or more space between them. It has a greater tendency to remain parallel to the pipe, thereby reducing bending loads or point loading. Shear stress reduces as grip length increases, up to a point in which softer gripping elements and friction instead of indentation could be used.

Conclusion

Joint restraint devices traditionally used on PVC-U will fit on comparable PVC-O pipe. However, it has been shown that property differences between PVC-U and PVC-O pipe demand that these differences be recognized when designing restraint devices. Of the five restraint devices tested, the Sliding Grip Cap (SGC) and the Internal C Grip (ICG) showed themselves to effectively restrain in all ASTM F1674 tests performed. Properly designed devices will effectively restrain PVC-O pipes.

Acknowledgements

The authors would like to thank S&B Technical Products / Hultec for sponsoring this paper. We would also like to thank Terramix Hydrostatic Laboratory, Santa Ana, Costa Rica, specifically Galina Potaskouev, Roberto Guardia and Janny Bustos for conducting the testing.

References

1. Fisher Craig, Quesada, Guido (2009) Tensile Testing of a Push-On Restrained Joint PVC Pipe, Technical Report, S&B Technical Products, Fort Worth, Texas, USA.
2. Najafi Mohammad, Ramírez Guillermo (2009) Testing of Bulldog PVC Restraint Joint for Trenchless Technology, University of Texas at Arlington, Arlington, Texas, USA.
3. Quesada Guido (2005) Characterization of a Successful Prototype for 12 Rieber Self Restrained Joint, Report HT0511r01, Mechanical Problem Solving, San José, Costa Rica.
4. Quesada Guido (2009) Bulldog Restraint System C900 8

- Performance Analysis for Horizontal Directional Drilling, Report HT091101, Mechanical Problem Solving, San José, Costa Rica.
5. Quesada Guido (2010) Simulation-Driven Design of Restrained Pipe Joints, Technical Paper, SIMULIA Customer Conference, Providence, USA.
6. Uni-Bell (2001) PVC Pipe Association, Handbook of PVC Pipe: Design and Construction 4th Edition, Dallas, Texas, USA.
7. American Society for Testing and Materials. Annual Book of ASTM Standards Volume 08.04, West Conshohocken PA, USA.

Copyright: ©2025 GM Quesada. This is an open-access article distributed under the terms of the Creative Commons Attribution License, which permits unrestricted use, distribution, and reproduction in any medium, provided the original author and source are credited.