

## Time Domain Reflectometry (TDR) System Application in Light Water Reactors In-Core (A Short Memorandum)

Bahman Zohuri<sup>\*</sup>, Seyed Kamal Mousavi Balgehshiri<sup>2</sup>, Ali Zamani Paydar<sup>2</sup> and Rahele Zadfathollah<sup>3</sup>

<sup>1</sup>Galaxy Advanced Engineering, Albuquerque, New Mexico, 87111, United States of America, Chief Executive Officer

<sup>2</sup>Physics and Energy Engineering Department, Amirkabir University of Technology, Tehran, Iran

<sup>3</sup>Department of Physics, K. N. Toosi University of Technology, P. O. BOX: 15875-4416, Tehran, Iran

### ABSTRACT

A Time Domain Reflectometry (TDR) is not a new technology in industry. This concept has been known for its monitoring and sending of signals for the detection of cable tampering in unattended radiation detection systems. The instrument concept under investigation would allow for unmanned cable integrity measurements, remote surveillance reporting, and the locating of cable faults and/or tampering. by a national laboratory such as the Pacific Northwest National Laboratory (PNNL). TDRs are a very simple instrumentation design configuration, using pulse signals to send the pulse through the cable. Their firmness depends on the width of the pulse sent by them. That is why narrow pulse signals are preferred. However, because narrow width pulses have high frequencies, they have a limitation. High-frequency signals get distorted inside large cables. However, in this short memorandum, not only do we introduce this instrument as reminder to the readers, what this device is, we also show its application as a water level monitoring instrument by Instrumentation and Control (I&C) as an In-Core tool within the family of Light Water Reactors (LWRs) during their safe operation domain and during their commercialization as Generation-IV (GEN-IV) of Small Modular Reactors (SMRs) as a consideration among the designers and engineers of these reactors within the nuclear industry. These devices could be developed and used extensively for measuring the water level In-Core of family of LWRs as a probe for measuring such levels in reactor vessel confinement and collecting surface runoff. It could be designed, developed, and calibrated, then field-tested accordingly. This device could be used as an additional safety factor in the computation of setpoints from Probabilistic Risk Assessment (PRA), specifically if we are using such a device in new Advanced Concept Reactor (ARC) technology of SMRs of GEN-IV.

### \*Corresponding author

Bahman Zohuri, Galaxy Advanced Engineering, Albuquerque, New Mexico, 87111, United States of America.

**Received:** January 24, 2023; **Accepted:** January 28, 2023; **Published:** February 02, 2023

**Keywords:** Advance Reactor Concept, Generation IV, Light Water Reactor, Boiling Water Reactor, Pressurized Water Reactor, Supercritical Water Reactor, Pressurized Heavy Water reactor.

### Introduction

Time-domain reflectometers use various kinds of signals as incident signals. Some of the transmitters use pulse signals. Some of them use fast-rise time step signals. Some of them also use impulse functions for signals. Typically, the waves reflected from the load impedance or due to the impedance of discontinuity are similar to the incident waves in their shapes. Nonetheless, the magnitude and other properties vary. If there is some change in the load impedance, the reflected wave makes the exact same change in its parameters to indicate the changes. For example, if the load impedance increases by one step, the reflected wave will also have an increased step. This property of reflected waves finds applications in many fields for the Time Domain Reflectometer. TDRs are used to ensure the cable's characteristic impedances and other impedance parameters are correct and there is no mismatch at connectors or joints.

To explain this further, one can look at the fact that if the far end of the cable is shorted, that is, terminated with an impedance of zero ohms, and when the rising edge of the pulse is launched down the cable, the voltage at the launching point "steps up" to a given value instantly and the pulse begins propagating in the cable towards the short. When the pulse encounters the short, no energy is absorbed at the far end. Instead, an inverted pulse reflects back from the short towards the launching end. It is only when this reflection finally reaches the launch point that the voltage at this point abruptly drops back to zero, signaling the presence of a short at the end of the cable. That is, the TDR has no indication that there is a short at the end of the cable until its emitted pulse can travel in the cable and the echo can return. It is only after this round-trip delay that the short can be detected by the TDR. The distance to the short can be calculated using the signal propagation speed in the cable under test. This matter is expressed in terms of the following form of equation:

$$\rho = \frac{Z_t - Z_0}{Z_t + Z_0} \quad \text{Eq. 1}$$

In Equation-1, the magnitude of the reflection is referred to as the reflection coefficient or  $\rho$  and the coefficient ranges from value 1 designated as *open circuit* to -1 as *short circuit*. The value of zero means that there is no reflection. In the above equation,  $Z_0$  is defined as the characteristic impedance of the transmission medium and  $Z_i$  is the impedance of the termination at the far end of the transmission line. Any discontinuity can be viewed as a termination impedance and substituted as  $Z_i$ . This includes abrupt changes in the characteristic impedance. As an example, a trace width on a printed circuit board doubled at its midsection would constitute a discontinuity. Some of the energy will be reflected back to the driving source; the remaining energy will be transmitted. This is also known as a scattering junction. On the basic aspect of Time Domain Reflectometry (TDR) can be said that it is a very established and old technology and widely used in cases of faulty cable location, measuring method for the determination of the following circumstances:

- The total length of a cable
- The location of low resistive cable faults
- The location of cable interruptions
- The location of joints along the cable

Time Domain Reflectometers (TDR) are a fast and easy method to measure cable lengths and to determine the locations of joints, short-circuits, and open faults. The basic operating principle of TDR is similar to that of RADAR, in which pulses are sent out into the cable, where they experience reflections due to changes in impedance at faults (open and shorted), joints, areas of moisture ingress, connectors and taps, and corroded neutral wires, among others. TDRs are great and easy tools to quickly determine the length of cable or locate short-circuits or low-resistive faults. TDRs can also be used in combination with High Voltage (HV) thumpers to locate high-resistive or intermittent faults in all types of cables. This is an application that TDR is used for by companies like HV Technologies, Inc. to identify a faulty cable in the electrical grids around the nation that connects the nodes and sources of generating electricity plants.

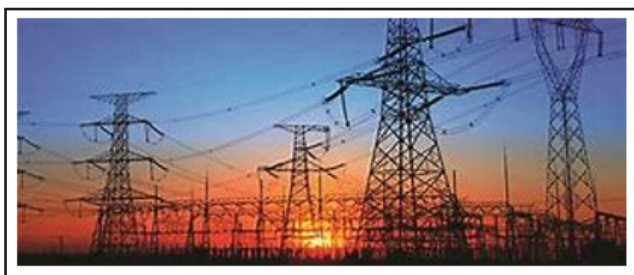

Figure 1: Grid Cabling Net

The working principle of TDR falls under the concept of a reflectometer and is the primary application of passive microwave components. A reflectometer is used in a vector network analyzer as it can measure various parameters like – reflection coefficient for the one-port network, scattering parameters for the two-port network. It can also be used as a “power monitor” or in place of a Standing Wave Ratio (SWR) meter or SWR-Meter.

**Note that**

The Standing Wave Ratio meter, SWR meter, ISWR meter (Current “I” SWR), or VSWR meter (Voltage “V” measures the standing wave ratio in a transmission line. The meter measures how out of sync a transmission line is with its load, which is usually an antenna.

Electronics technicians use it to adjust radio transmitters and their antennas and feedlines to be impedance matched so they work together properly, and evaluate the effectiveness of other impedance matching efforts. See Figure: 2

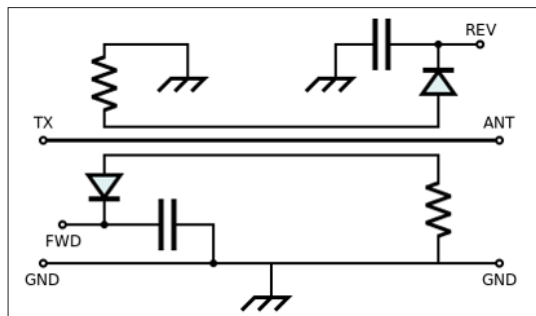

Figure 2: A Simple Directional SWR Meter

In summary, the cable waits for the reflection. If there are some defects or mismatches in the transmission line or the cable, part of the incident wave is reflected. TDR receives the reflected wave and then analyzes it to locate and measure the faults. But if there are no defects or everything is fine, then the signal reaches the far end without reflection, and the cable is considered acceptable. The working principle of a Time Domain Reflectometer is almost identical to the working principle of a RADAR.

The TDR analyzes the reflected wave by interpreting the amplitude of the reflected wave, which determines the impedance of discontinuity. The reflected pulses also determine the distance of the reflected wave, which further determines the fault’s location. Figure-3 step signals or energies.

Then it observes the reflected energy or the signals subsequently. The discontinuity of impedance is measured and analyzed by the reflected pulses of energies, as the amplitude, magnitude, and waveforms help in analyzing.



Figure 3: Reading from a TDR

The following expression gives the relation between the load impedance and the magnitude of the reflected wave:

$$P = \frac{R_L - Z_0}{R_L + Z_0} \tag{Eq. 2}$$

In above equation,  $Z_0$  is the characteristic impedance of the transmission line or the coaxial cable and  $R_L$  is connected load resistance. See Figure: 4

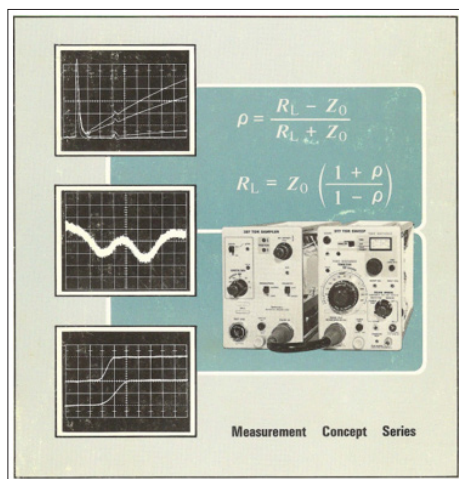

Figure 4: TDR Measurements

Any impedance discontinuity is observed as the termination impedance, and the termination impedance replaces it. The process consists of rapid changes in the characteristic impedance of the transmission lines.

### Time Domain Reflectometry Drives (TDR) Water-Level Measurement

On the soil-surface on earth, the water content of soils can be profiled as a function of depth with the help of Neutron logs or by Time Domain Reflectometry (TDR) [1]. In theory, repeat measurements with these instruments can be used to estimate change in soil-water storage empirically. However, these methods are of limited value when estimates are to be made over large areas. See Figure: 4



Figure 5: A Portable TDR Instrument for Measuring Soil Water Content (Photo by Maja Krzic, University of British Columbia, Vancouver Bc)

The concept of “field water capacity,” used widely by soil scientists and agronomists, denotes the quantity of water remaining in a unit volume of an initially wet soil from which water has been allowed to drain by gravity over a day or two, or the rate of drainage has become negligible [1]. An additional advantage is that TDR can be automated (so as to be remotely controlled), and through multiplexers, it is possible to employ several probes simultaneously with a single measurement instrument. Such characteristics and methods can be easily applied for In-Core I&C in any family of Light Water Reactor (LWRs). A simple design study of TDR with longer probes can be taken into consideration for the utilization of TDR probe instrumentation as a way of measuring water-level in these types of reactors in place of devices such as the Heated Junction Thermo Coupled (HJTC) device for the same purpose (i.e., Water-Level Measurement) that is also suggested by experts

in the field of nuclear reactor designs of LWRs. See Figure-6

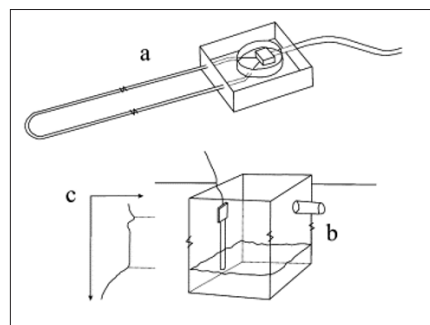

Figure 6: Simple TDR Design in a Tank Container

The concept of “field water capacity,” used widely by soil scientists and agronomists, denotes the quantity of water remaining in a unit volume of an initially wet soil from which water has been allowed to drain by gravity over a day or two, or the rate of drainage has become negligible [1].

An additional advantage is that TDR can be automated (so as to be remotely controlled), and through multiplexers, it is possible to employ several probes simultaneously with a single measurement instrument. Such characteristics and methods can be easily applied for In-Core I&C in any family of Light Water Reactor (LWRs). A simple design study of TDR with longer probes can be taken into consideration for the utilization of TDR probe instrumentation as a way of measuring water-level in these types of reactors in place of devices such as the Heated Junction Thermo Coupled (HJTC) device for the same purpose (i.e., Water-Level Measurement) that is also suggested by experts in the field of nuclear reactor designs of LWRs. See Figure: 6

### Light Water Reactors Characteristics

The Light Water Reactors (LWRs) are a type of thermal-neutron reactor that uses normal water, as opposed to heavy water, as both its coolant and neutron moderator; furthermore, a solid form of fissile elements is used as fuel. There are three types of LWR listed here:

1. Boiling Water Reactor (LWR)
2. Pressurized Water Reactor (PWR)
3. Super Critical Water-cooled Reactor (SCWR)

The existing U.S. nuclear fleet has a remarkable safety and performance record. Extending the operating lifetimes of current plants beyond 60 years and, where possible, making further improvements in their productivity will generate early benefits from research, development, and demonstration investments in nuclear power.

Since they all use normal water in their core vessels, they can be good containers for TDR to be inserted in them as probe for water level measurements in real time and remotely, as well as an unattended measurement system.

But as the number of systems and instruments grows, it makes it harder to deploy them quickly and put in place measures to make sure the data is real.

### Conclusion

TDR makes use of the dielectric constant,  $\epsilon_{app}$ , of water shown as Equation-3, to determine the volumetric water content of soil. We are going to see how the dielectric constant of a soil sample depends on the amount of water in it. We measure it and then use

an empirical relation, which equates the volumetric water content to the dielectric constant.

$$\varepsilon_{app}(f) = \frac{\varepsilon_r'}{2} \left( 1 + \sqrt{1 + \left\{ \frac{\varepsilon_r''(f) + \frac{\sigma}{2\pi f \varepsilon_0}}{\varepsilon_r'(f)} \right\}^2} \right) \quad \text{Eq. 3}$$

where  $\varepsilon_0 = 8.854 \times 10^{-12}$  F/m is the dielectric permittivity of free space,  $f$  is the frequency,  $\varepsilon_r'(f)$  describes energy storage,  $\varepsilon_r''(f)$  accounts for the dielectric losses, and  $\sigma$  is the static electric conductivity.

Time Domain Reflectometry (TDR) instrumentation is widely used in hydrology and soil science for accurate and flexible measurements of soil water content. Water content is measured using suitable measuring probes of varying design, with the 'global' or a locally derived calibration function relating the TDR measured soil dielectric constant to volumetric water content [4-6]. TDR measurements can be made manually or automatically using computer software. Only automated TDR systems are practical for projects where short duration processes such as surface runoff and water erosion are investigated [7-9].

In summary, TDR is largely used for diagnostic and monitoring purposes in different fields, and this is due to its high versatility, accuracy, and relatively low implementation costs, as well as the possibility of carrying out continuous real-time measurements. An additional advantage is that TDR can be automated (so as to be remotely controlled), and through multiplexers, it is possible to employ several probes simultaneously with a single measurement instrument.

## References

1. Narasimhan TN (2009) Hydrological Cycle and Water Budgets. Encyclopedia of Inland Waters 714-720.
2. Topp GC, Davis JL, Bailey WG, Zebchuck WD (1984) The measurement of soil water content using a portable TDR hand probe. Can J Soil Sci 64: 313-321.
3. Zegelin SJ, White I, Jenkins DR (1989) Improved field probes for soil water content and electrical conductivity measurement using time domain reflectometry. Water Resour Res 25: 2367-2376.
4. Roth CH, Malicki MA, Plagge R (1992) Empirical evaluation of the relationship between soil dielectric constant and volumetric water content as the basis for calibrating soil moisture measurements by TDR. J Soil Sci 43: 1-13.
5. Topp GC, Davis JL, Annan AP (1980) Electromagnetic determination of soil water content: measurement in coaxial transmission lines. Water Resour Res 16: 574-582.
6. Jacobsen OH, Schjønning P (1993) A laboratory calibration of time domain reflectometry for soil water measurement including effects of bulk density and texture. J Hydrol 151: 147-157.
7. Baker JM, Allmaras RR (1990) System for automating and multiplexing soil moisture measurements by time domain reflectometry. Soil Sci Soc Am J 54: 1-6.
8. Heimovaara TJ, Bouten W (1990) A computer-controlled 36-channel time domain reflectometry system for monitoring soil water contents. Water Resour Res 26: 2311-2316.
9. Thomsen A (1994) Program AUTOTDR for making automated TDR measurements of soil water content. User's Guide. SP Report No. 38, Danish Institute of Agricultural Sciences, Tjele, Denmark <https://agris.fao.org/agris-search/search.do?recordID=DK9520047>.

**Copyright:** ©2023 Bahman Zohuri, et al. This is an open-access article distributed under the terms of the Creative Commons Attribution License, which permits unrestricted use, distribution, and reproduction in any medium, provided the original author and source are credited.